

# Installation Manual

## For Massage Bathtub Model CSBTM2030

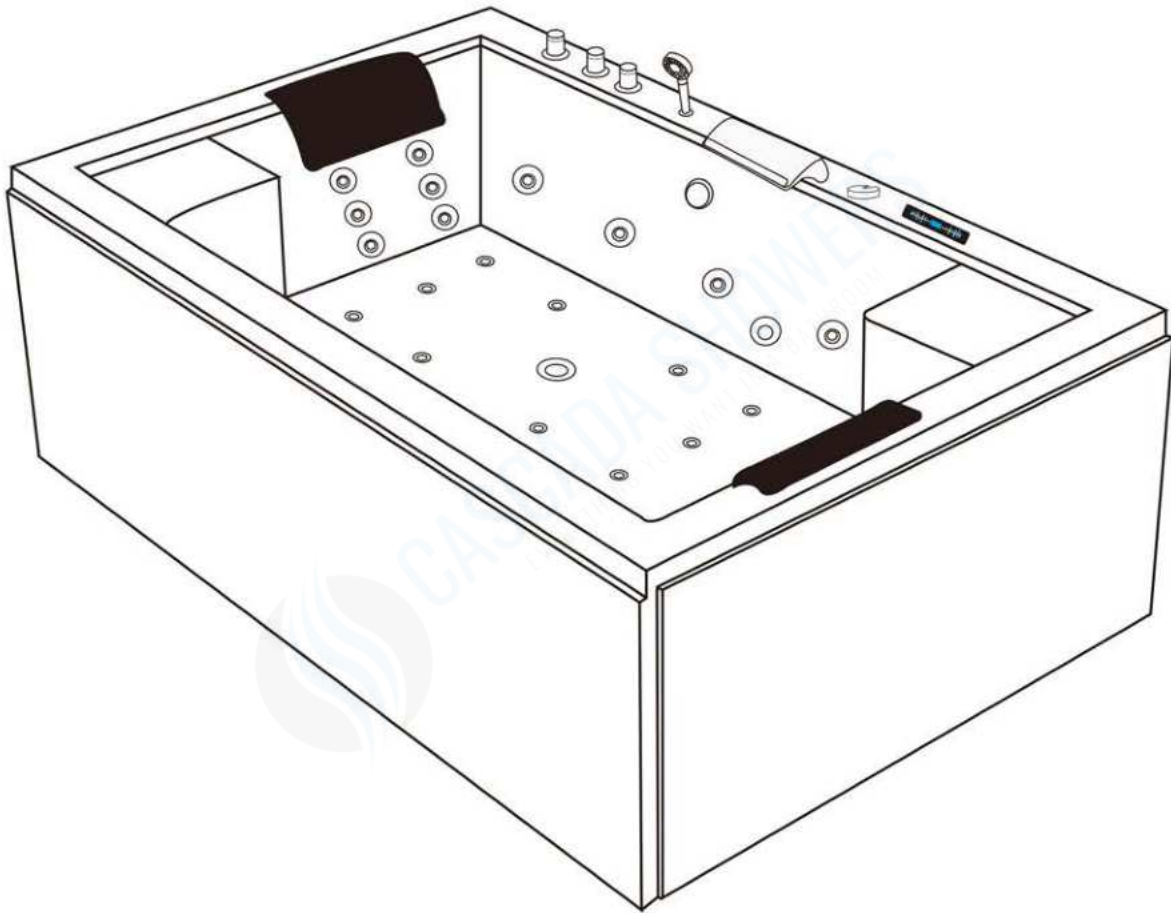

**Size: 71"x47"x23" (1800x1200x580mm)**

# Functional Introduction

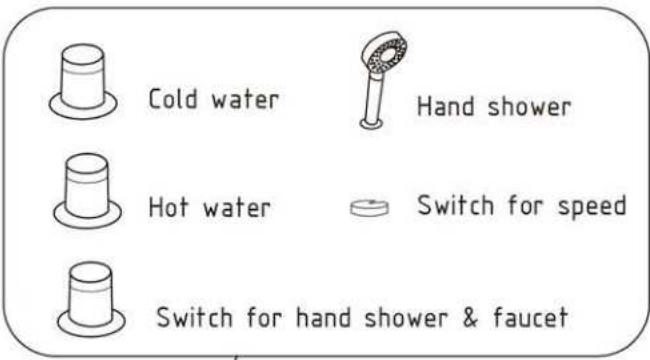

Cold water

Hot water

Switch for hand shower & faucet

Hand shower

Switch for speed

A rounded rectangular callout showing a control panel with six knobs and a hand shower head. The knobs are arranged in two columns: three on the left and three on the right. The hand shower head is on the right side of the panel.

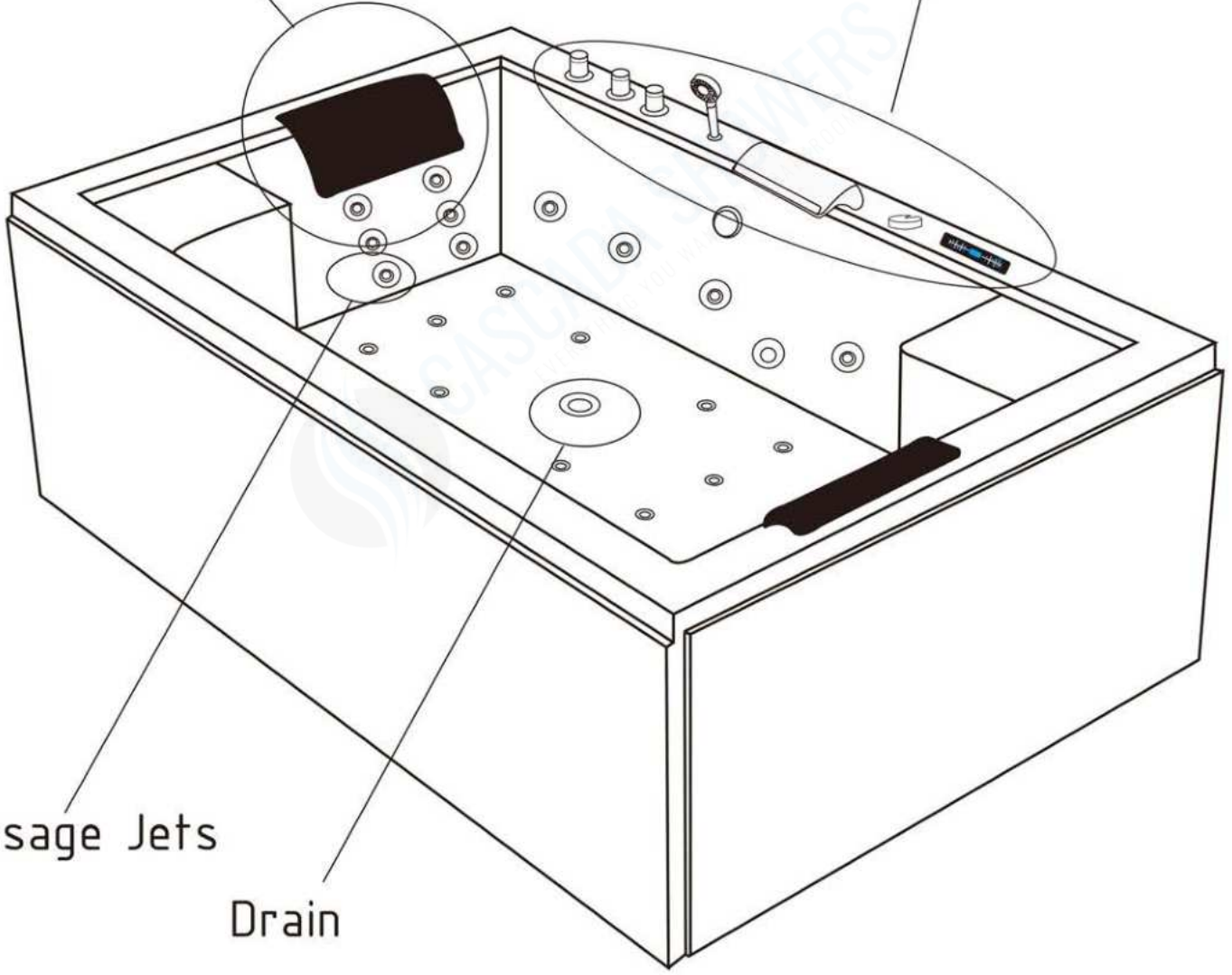

Massage Jets

Drain

# Water & Electricity Position Design

Length unit: inch

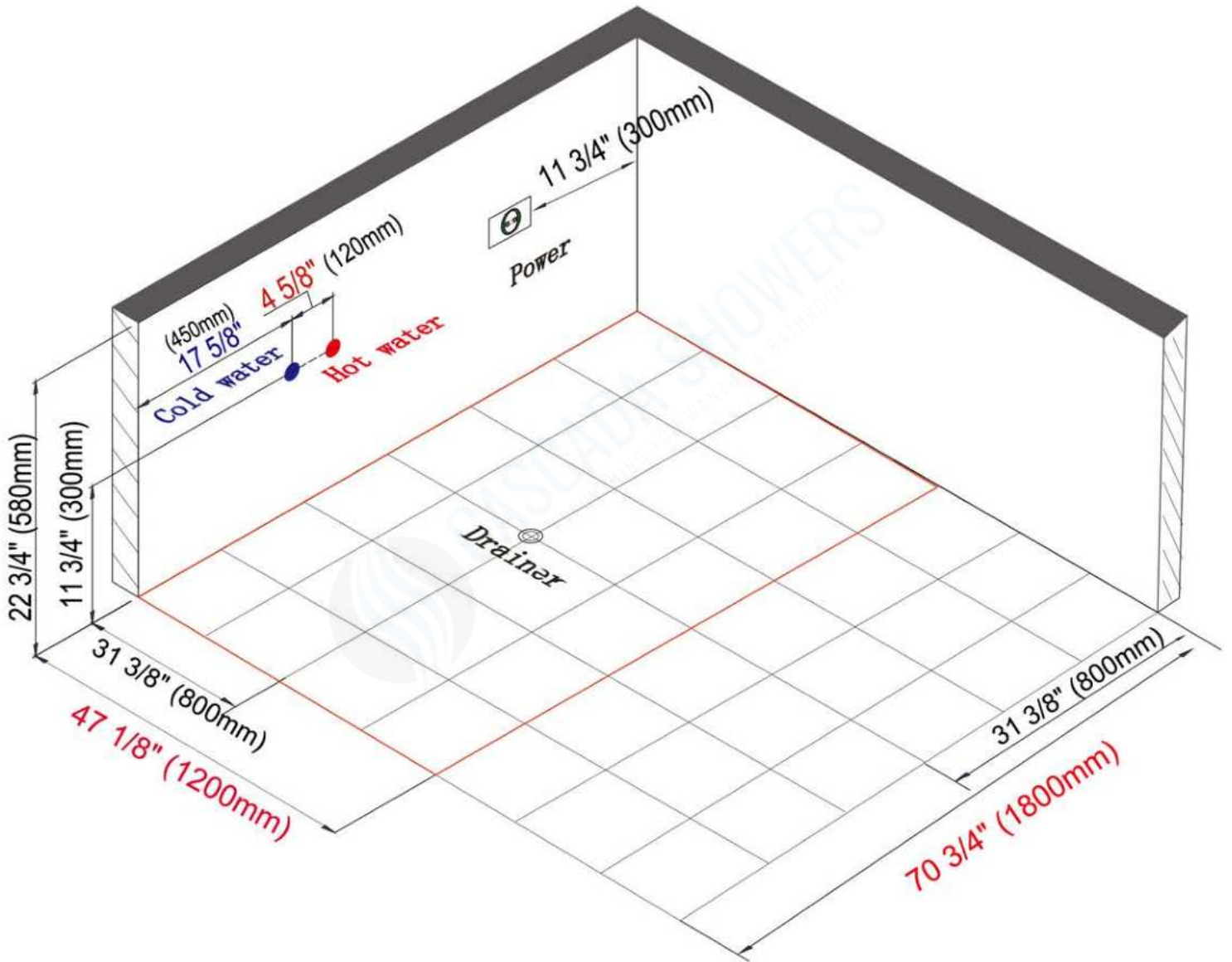

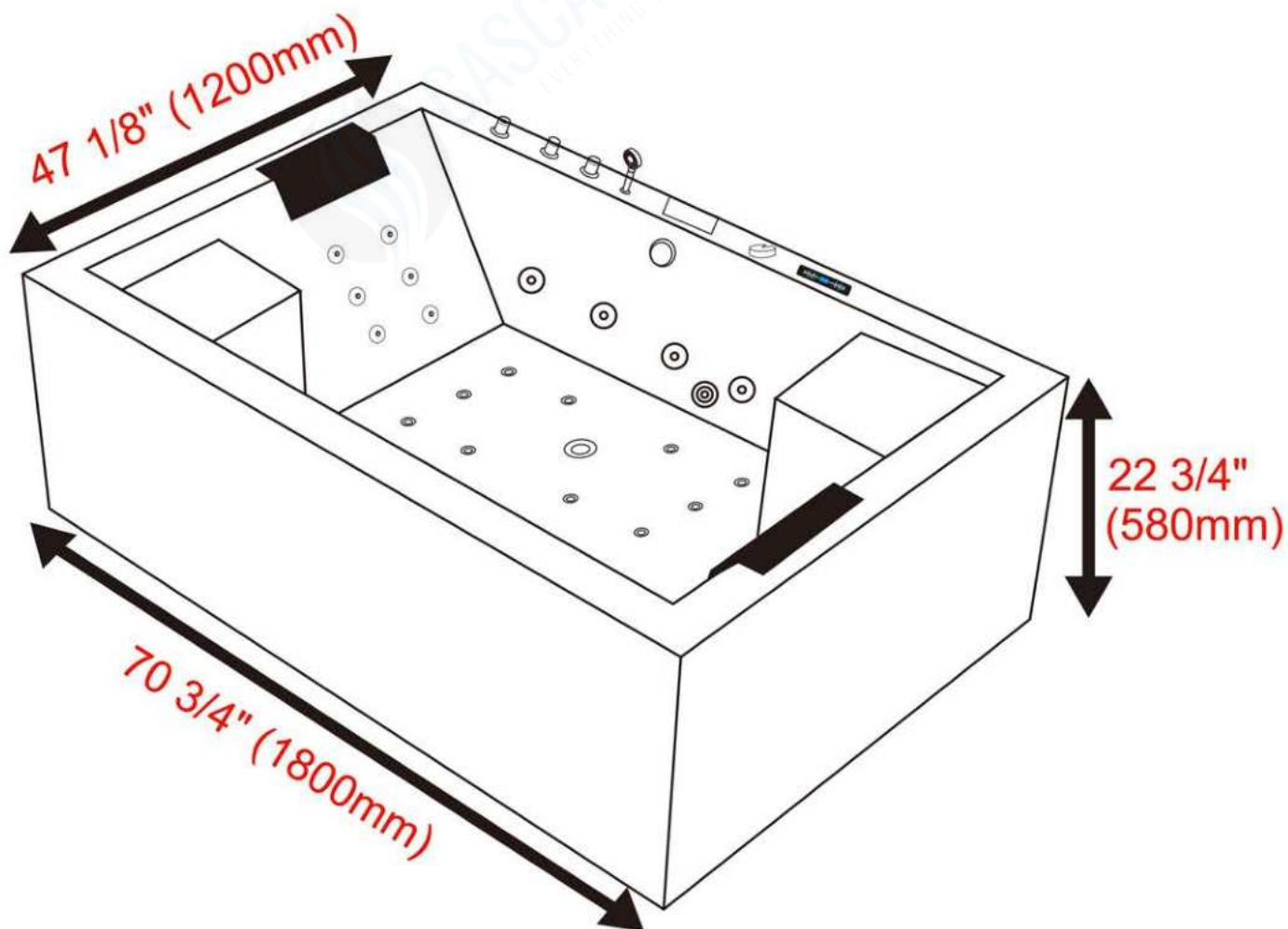
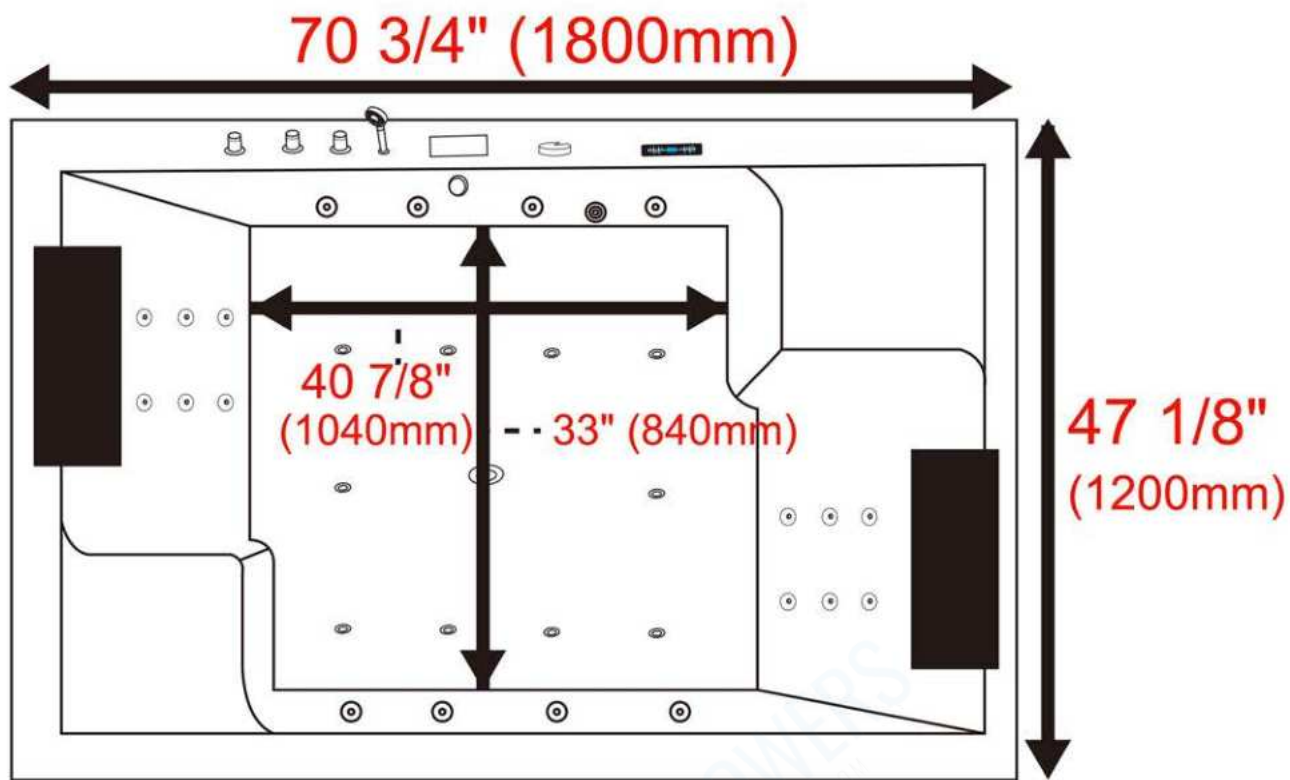

# Power Request

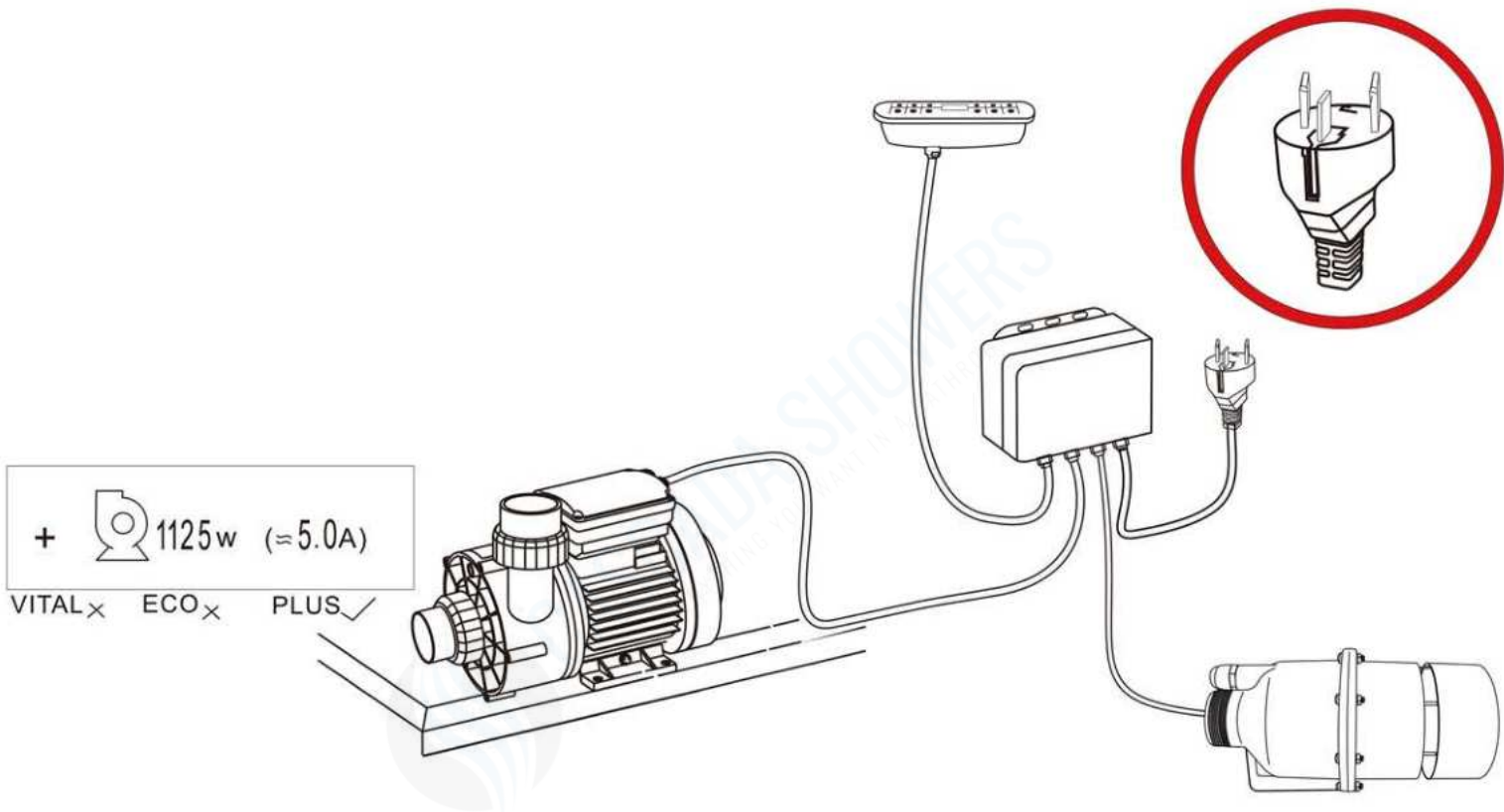



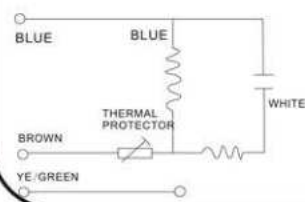

+  1125w (≈5.0A)  
 VITAL~~x~~ ECO~~x~~ PLUS✓

**DXD PUMP**

MODEL DXD-315 E AC 110V 60Hz 1125W CLASS F IPX5  
 MAX WATER TEMPERATURE 50°C 15u F/450V Hmin 1m



 Ground properly!  
 Do Not Start Pump  
 Without Water!

**DXD AIR PUMP**

MODEL DXD-6B-350 110V 60Hz 350W  
 S1 CLASS 155(F)  
 IP X5

  

BAR CODE:

# Pumps Position

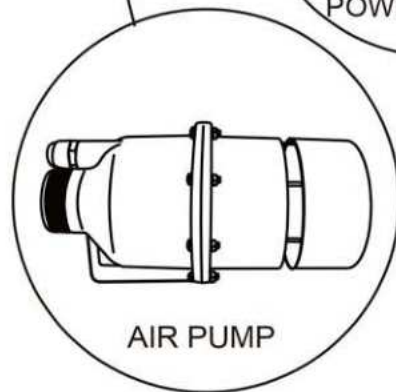
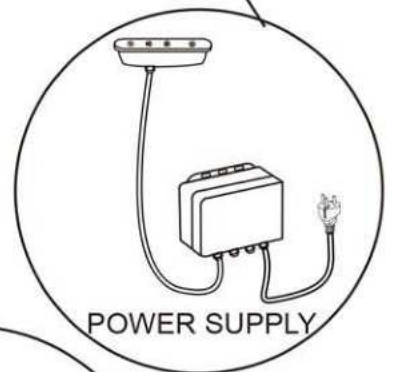
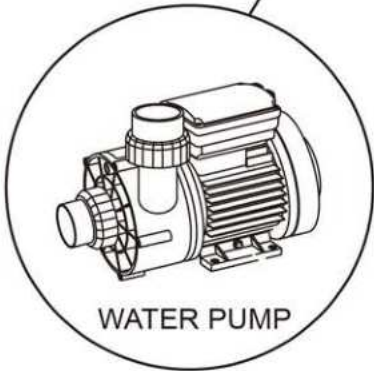
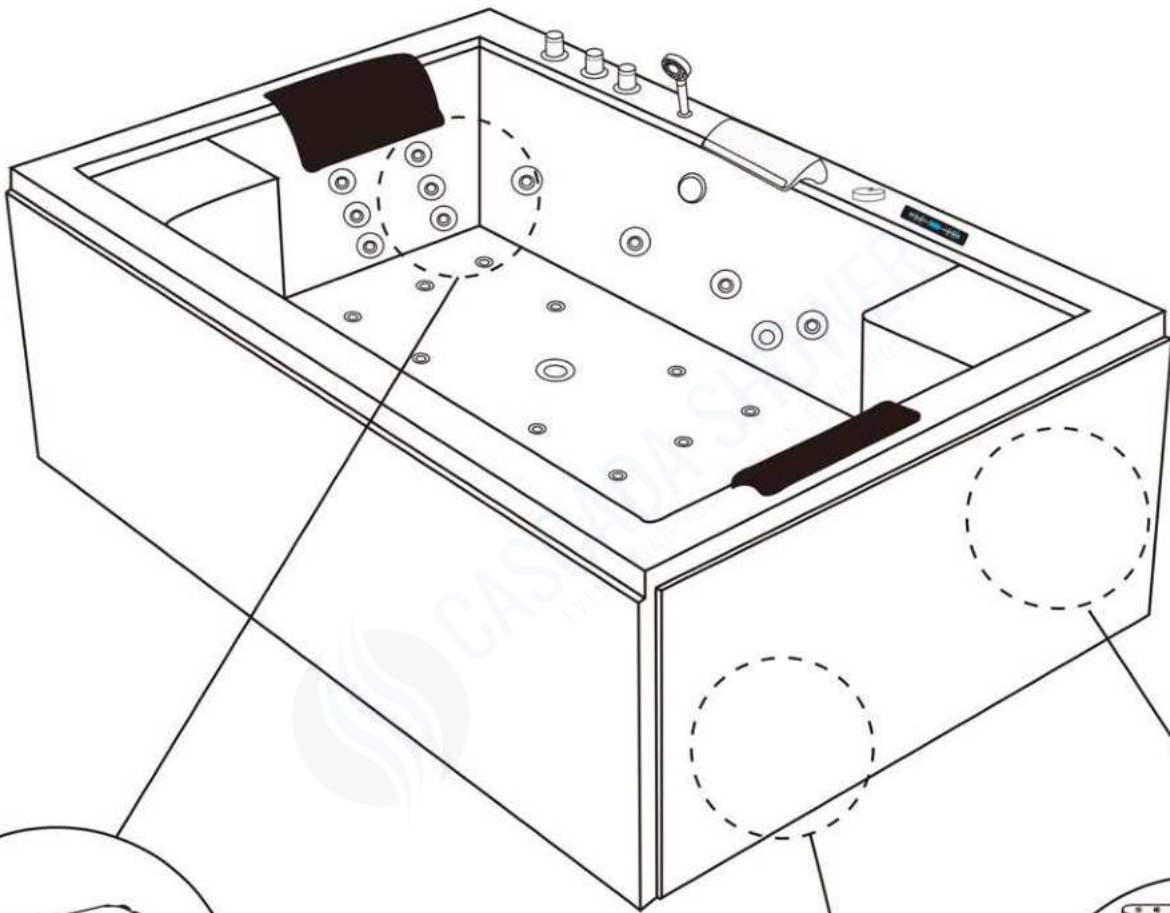

# Accessories Installation

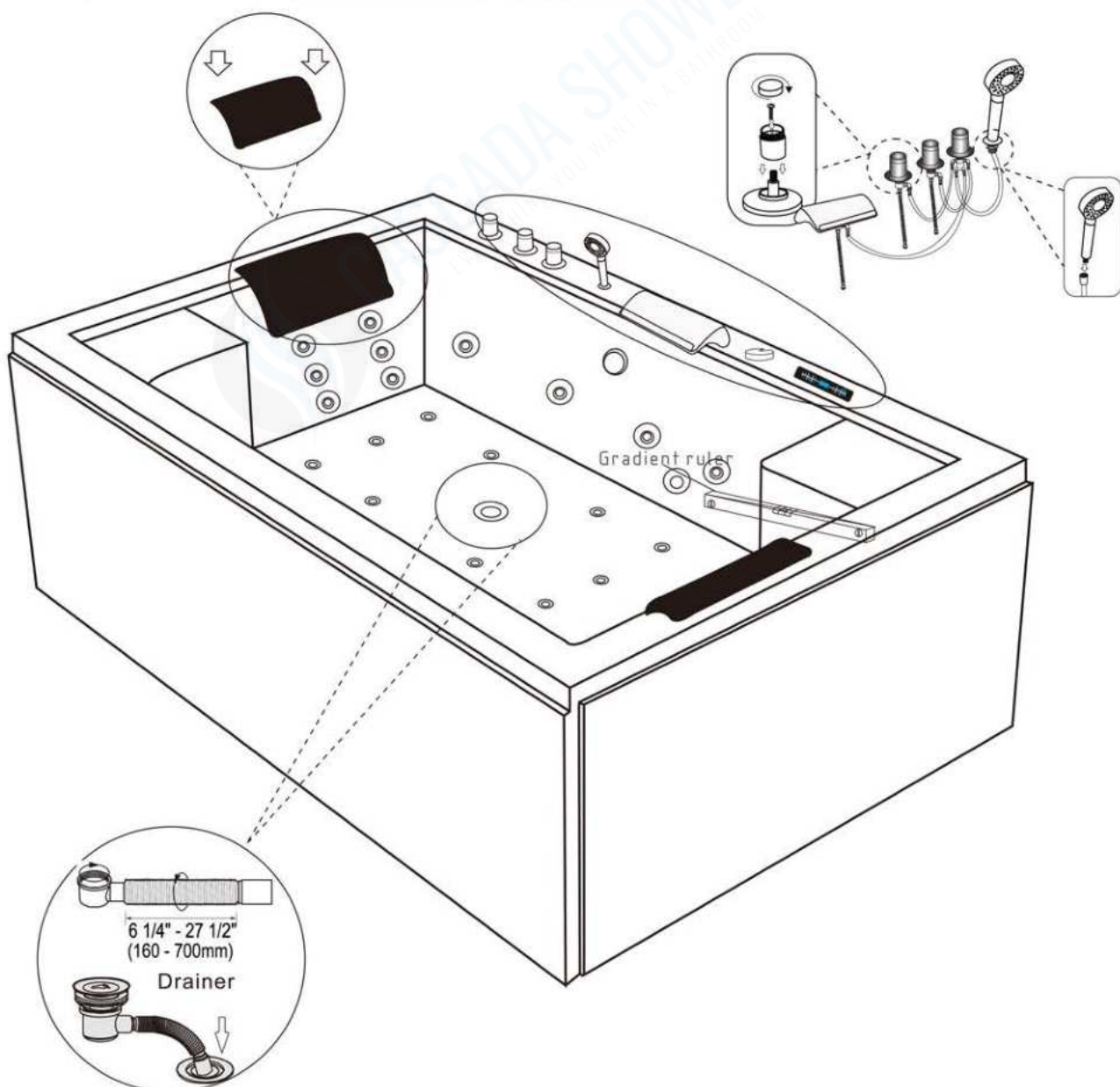
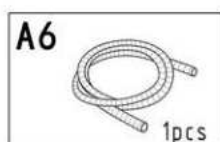
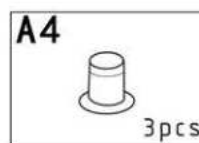
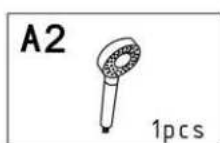
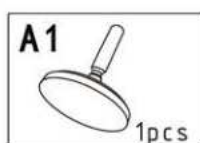
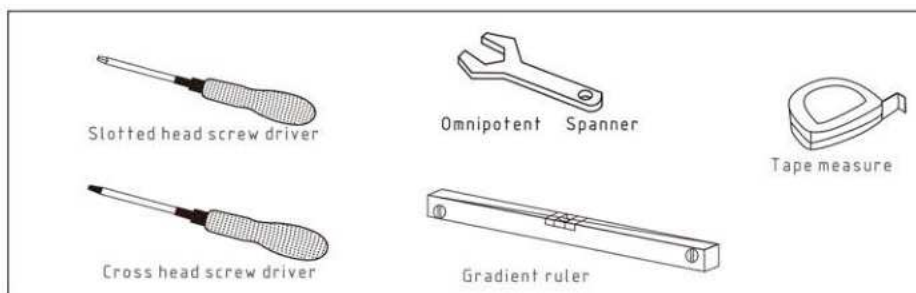

# Functional Instructions

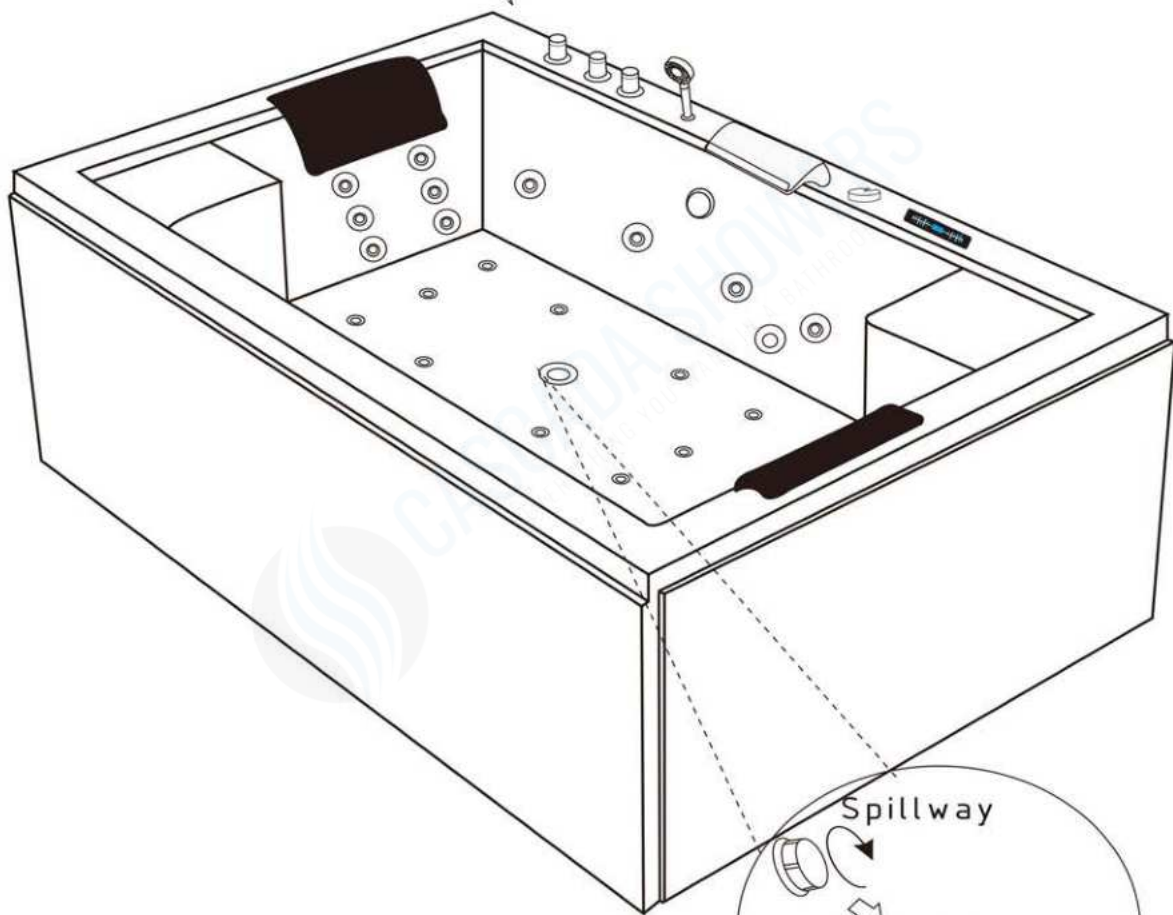
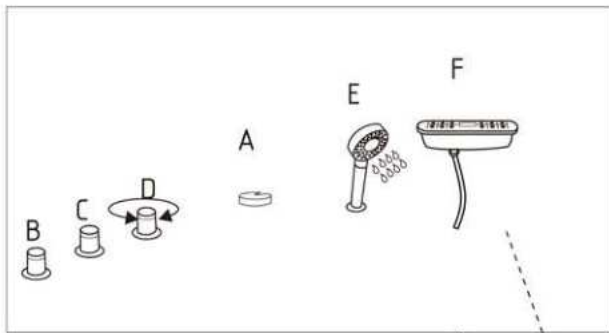

Turn round G, the water runs faster.

Turn round B, cool water.

Turn round C, hot water.

Turn round D, water comes from E.

# Hardware installation

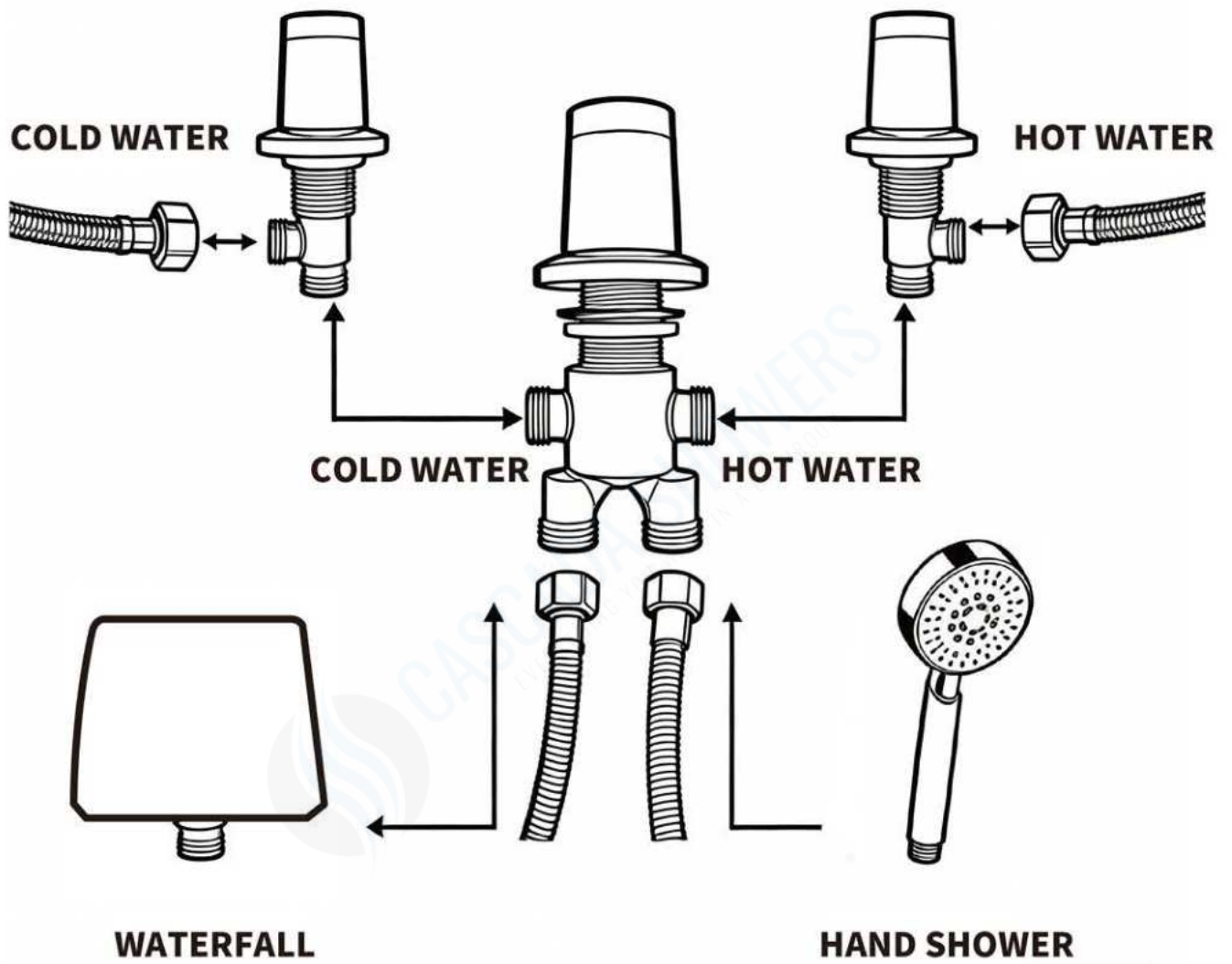

# Schematic diagram of the installation

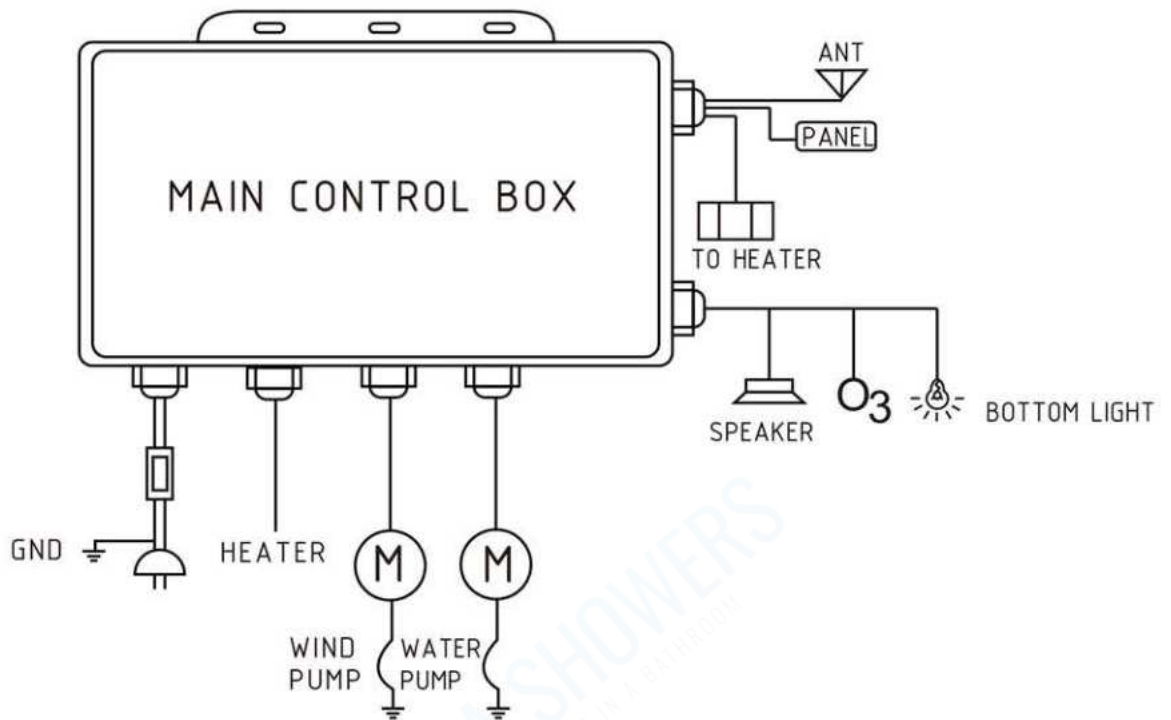

# Schematic diagram of the panel

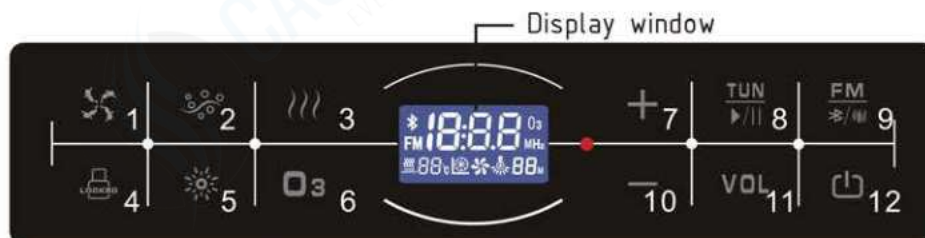

- |                         |                                  |
|-------------------------|----------------------------------|
| 1. water pump           | 7. adjusting plus                |
| 2. wind pump            | 8. Frequency button              |
| 3. thermostatic heating | 9. FM radio or blue tooth button |
| 4. lock                 | 10. adjusting minus.             |
| 5. bottom light         | 11. Volume button                |
| 6. ozone sterilization  | 12. Power ON/ OFF button         |

# Operation

## instruction and direction



Power ON/OFF switch

Push down the switch,the controller is open,its status light is on,and other function can be used only when power is ON.



Bottom light ON/OFF button

Push down the button,the light is on;repeat the operation,the light is off.



Water pump ON/OFF button

Push down the button,the water pump is on:repeat the operation,the water pump is off.



Air pump on/off button

Push down the button,the air pump is on:repeat the operation,the air pump is off.

**O3** Ozone sterilization button

Push down the button,Ozone sterilization is on;Repeat the operation,o3 will be stopped in 15 minutes when o3 is switch.

### Thermostatic heating

when the water pump is open,you can push down the button

))) Then the Heater starts to run normally.when it is pressed on long time,you can press + - to set the water temperature.The temperature setting range is:30 to 50 °C.Temperature display window will flash when the temperature is set,And will display current water temperature in few seconds.



FM Radio & blue tooth ON/OFF

**VOL + -** volume adjusting minus and volume adjusting plus button.

**TUN + -** They can turn the radio step by step when they are pressed on short time. They can search the station when they are pressed on long time, "it can select memory channel. Push down the button again, the blue tooth is on. Open the Bluetooth function of the controller, then search for Bluetooth devices through devices such as mobile phone, which will prompt you to enter password, the universal code is: 000000, if the devices such as mobile phone can't connect to Bluetooth of the controller, please restart your mobile phone and the controller.

Notice:

Do not open the water pump When there is not enough water.

## Run Environment

- ① POWER: AC 110V    ② Bottomlight: AC 12V
- ④ 03: AC 12V    ⑤ Air adjust: AC 110V
- ⑥ Water/Windpump: AC 110V

## Notes of user

- ① Please read the instruction carefully when install the product, so that you can do it effectively in time.
- ② User should pay attention to the high-voltage on product smarked signs, Not to touch their locations, ensure Personalsafety;

- ③ Don't expose the controller to the moist or high temperature environment to prevent fire or electric shock.  
Please towel the controller after using it.
- ④ Please keep water clean, no solid debris left. Otherwise, it will jam the backwater and the pipeline, resulting in damaging the equipment or fittings. If jam happened, please turn off the power to clean stems immediately, then restart it.
- ⑤ Please do not pull any of the output lines, not beat or throw the equipment at random. Otherwise, crusts or inner parts will be broken.
- ⑥ Don't open the cover of the controller for there are dangerous parts in it. Only qualified servicemen are allowed for maintenance.
- ⑦ The used power supply must be in line with the specified voltage value shown on the controller, otherwise it is not allowed to be used even burns out the controller.
- ⑧ The intervals of continuous power on and off must be over 30s for extending the use life of the controller.
- ⑨ Please do not plug or pull the control panel with electricity, otherwise the devices will be damaged or unusual conditions will appear. At the moment, turn off the power in seconds, restart it.
- ⑩ Please insert fittings (such as: light, speaker, valve, ozone sterilization, water pump, wind pump, steam generator, etc.) into corresponding output ports of equipment correctly,

## Solutions of basic problems

- ① Q: why do not thermostat heating run?  
A: Check whether you adjust the temperature of control panel to the water temperature or higher at room temperature.

② Q: Press lights, ozone, speakers, fan, air-conditioning and other functions, but why don't they start to run?

A: Check whether the plug-in terminals contacts with each other well; if lights and ozone sterilization still fails to run, please turn on the fuse and ensure if it has blown out then you can contact with my company staff.

③ Q: If speaker is voiceless, why is that?

A: Please open the FM radio, check whether the volume button on the panel has been increased. If not, you can contact with my company staff. Reference to the following reasons: Speaker's terminal contacts badly; Internal chips had burned out; the corresponding relay is open; the Speaker is broken.

④ Q: If there is too little FM radio programs received or in noisy, why is that?

A: Please check the location of the antenna, release antenna or to remove it to another appropriate location.

